

# W50

Three-phase Electric Motor  
Commercial Catalogue - IEC Market

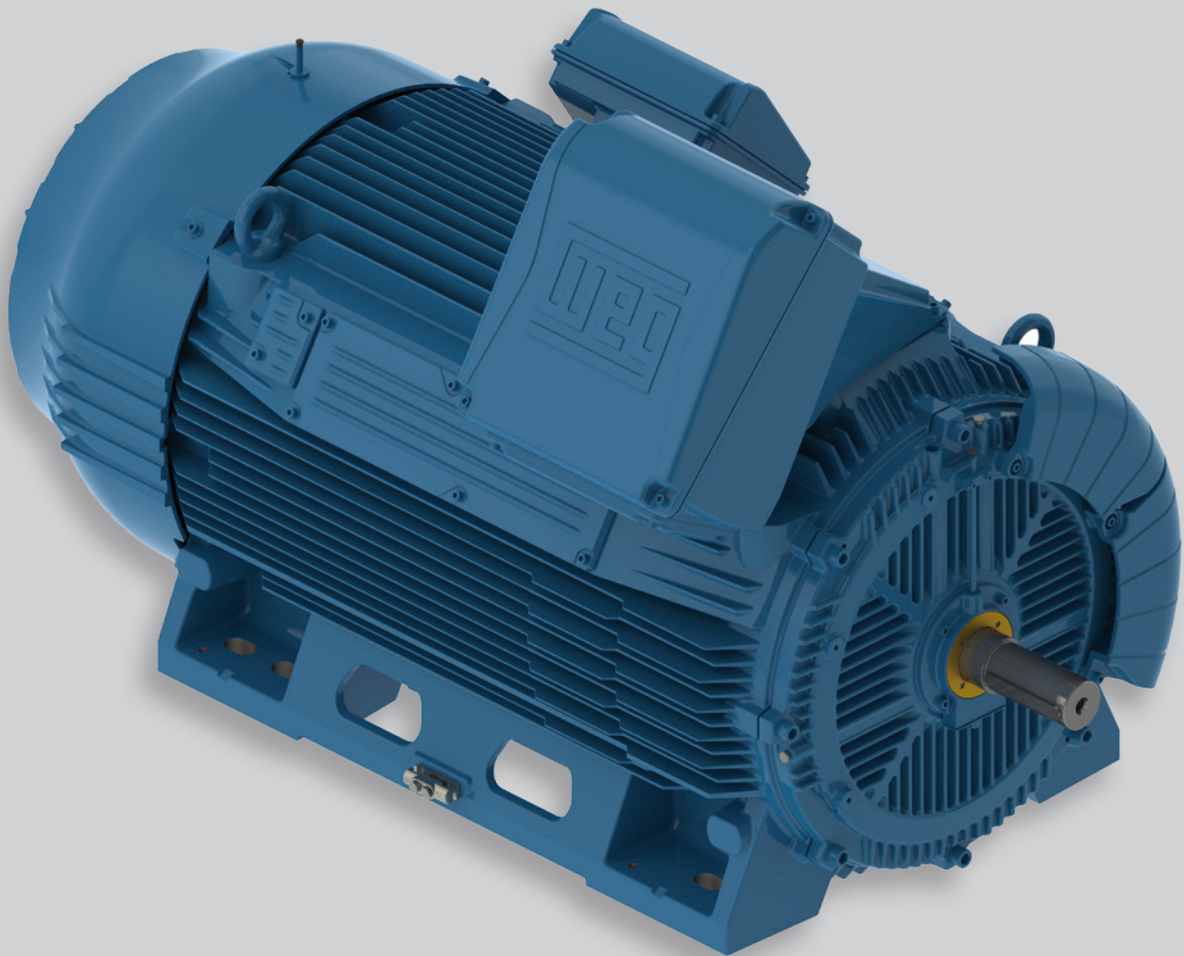

Motors | Automation | Energy | Transmission & Distribution | Coatings

## W50

WEG W50 motors offer not only **excellent performance**, but comply with the strictest **efficiency** and **safety** criteria in the most severe applications. The compact design provides **high performance**, while their robust frames ensure **low vibration levels**.

The mechanical concept not only optimizes characteristics like mass and length, but also offers product **versatility** and **reduced maintenance**.



### Standard Features

- Rated output: 75 to 1250 kW
- Number of poles: 2 to 12
- Frame sizes: 315H/G to 450J/H
- Frequency: 50 and 60 Hz
- Voltage: 380 to 6600 V
- Service factor: 1,00
- Insulation class: F
- Degree of protection: IP55
- Mounting: B3
- Cooling method: TEFC – Totally enclosed fan cooled (IC411)
- Frame, endshields, fan cover and terminal box material: FC-200 cast iron
- Shaft material: AISI 4140
- Thermal protection:
  - Windings: Pt-100 3 wire, 2 per phase
  - Bearings: Pt-100 3 wire, 1 per bearing
- Grease lubricated ball bearings
- Bearing seal: Taconite labyrinth
- Vibration Level: Grade A according IEC 60034-14
- Lubrication: Mobil Polyrex EM Grease
- Painting plan: C4 - “Medium” Durability according to ISO 12944
- Color: RAL 5009 (Blue)
- Dual Voltage Space Heaters
- Automatic drain plug

### Optional Features

- Other mounting configurations: B35, V1, V5, V6 etc.
- Degree of Protection: IP56, IP65, IP66
- Cooling method: TEBC – Totally enclosed blower cooled (IC 416)
- Surrounding muffler
- Service factor: 1.15
- Bearings:
  - Sleeve bearings
  - Insulated drive end bearing for inverter duty applications
  - Cylindrical roller bearing
  - Shaft grounding brush
  - Bearings designs for vertical mounting normal and high thrust applications
- Seal: INPRO/SEAL®
- Vibration level: Grade B according IEC 60034-14
- Bearing and winding thermal protection: thermistors or thermostats
- Cable glands
- Drip proof canopy for shaft down applications
- Internal tropicalized painting
- Encoder
- Suitable for VFD applications
- Main terminal box in welded steel
- Additional terminal box: For “Y” connection with access to the neutral terminal
- Non-contact / contact thermometer with gauge
- Stainless steel fasteners

W50: Robust, compact, efficient and reliable in the most severe operating conditions.

## Features and benefits

### Mechanical Design

- Compact and robust frame
- Low noise levels (82 dB(A) at 3600rpm)
- Optimum efficiencies due to low mechanical losses
- Innovative design of the DE endshield fins for maximum heat dissipation
- Uniform temperature distribution across the motor frame due to the exclusive internal ventilation system
- Easy access to accessories
- State of the art air deflector on the DE endshield ensuring lower bearing temperature

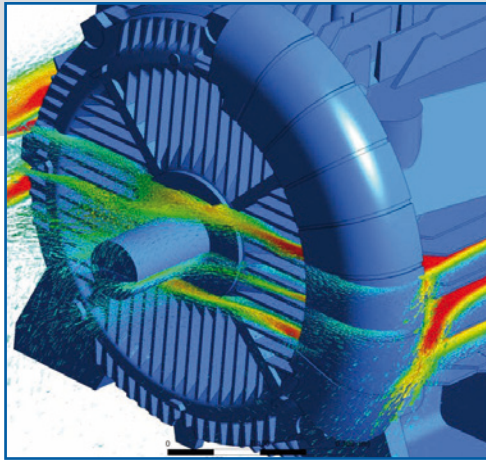

### Electrical Performance

- Suitable for VFD applications
- High output/weight ratio
- Low starting current
- WISE® insulation system for low voltage motors
- VPI insulation system for medium voltage motors

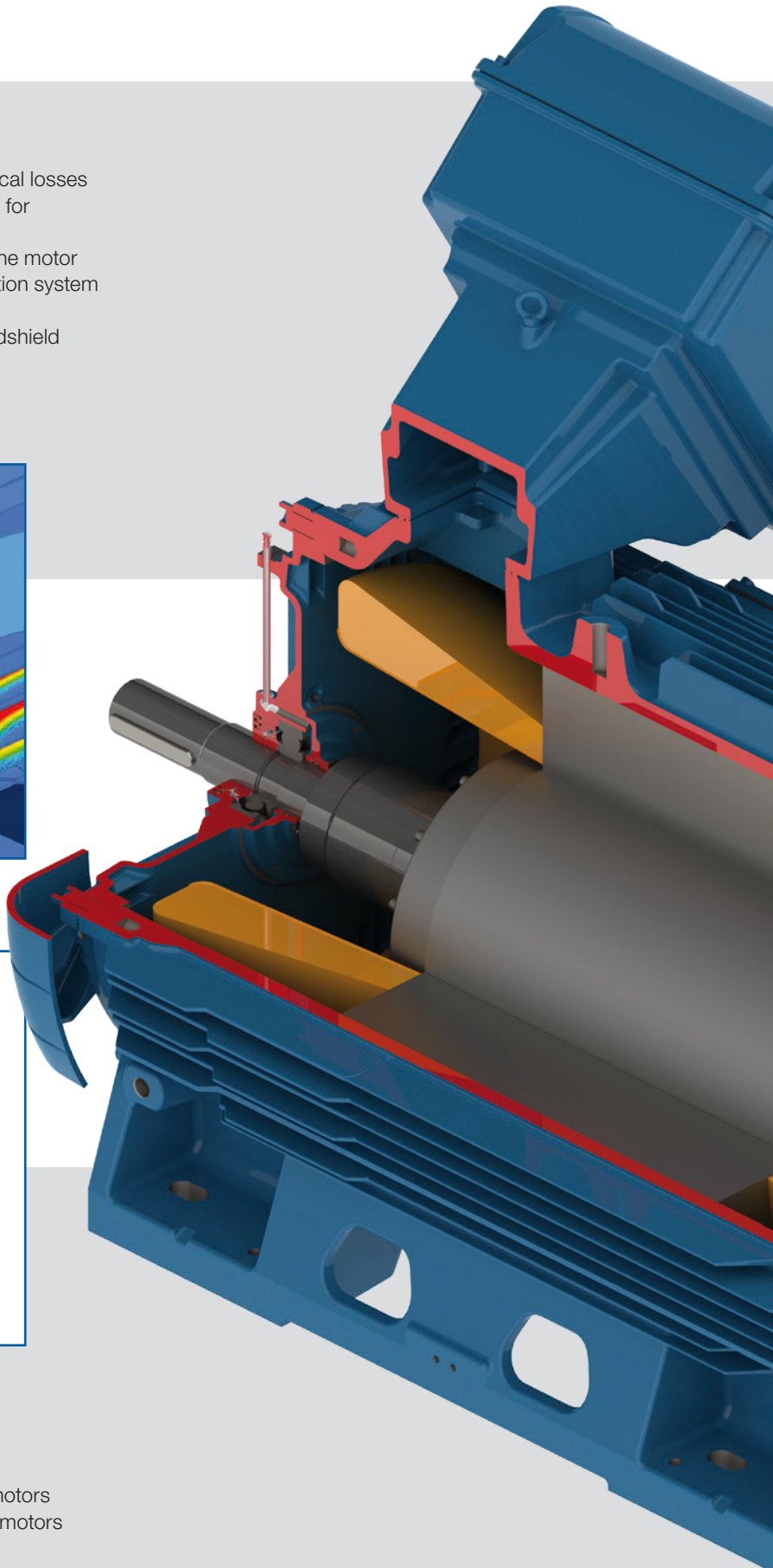

Versatility

- Modular forced ventilation kit
- Wide range of options and accessories
- Terminal box location on either left or right side

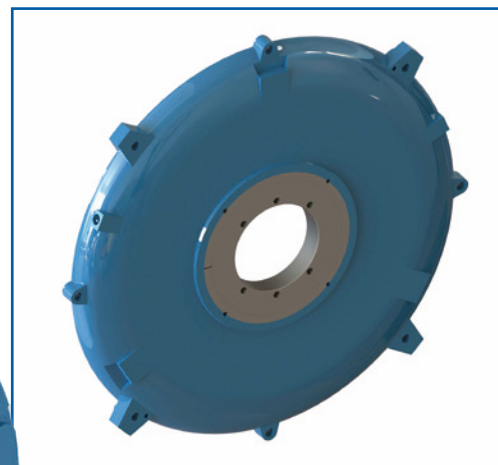
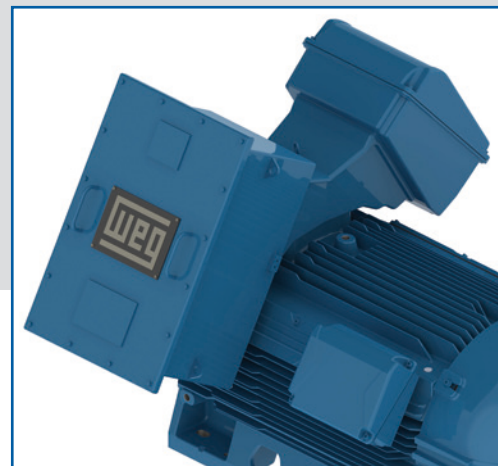

- Insulated NDE endshield for all motors
- Wound stator winding and bearings with temperature sensors
- Low bearing temperatures ensure longer lubrication intervals and extended bearing lifetime
- Low vibration levels ensure longer motor lifetime

Reliability

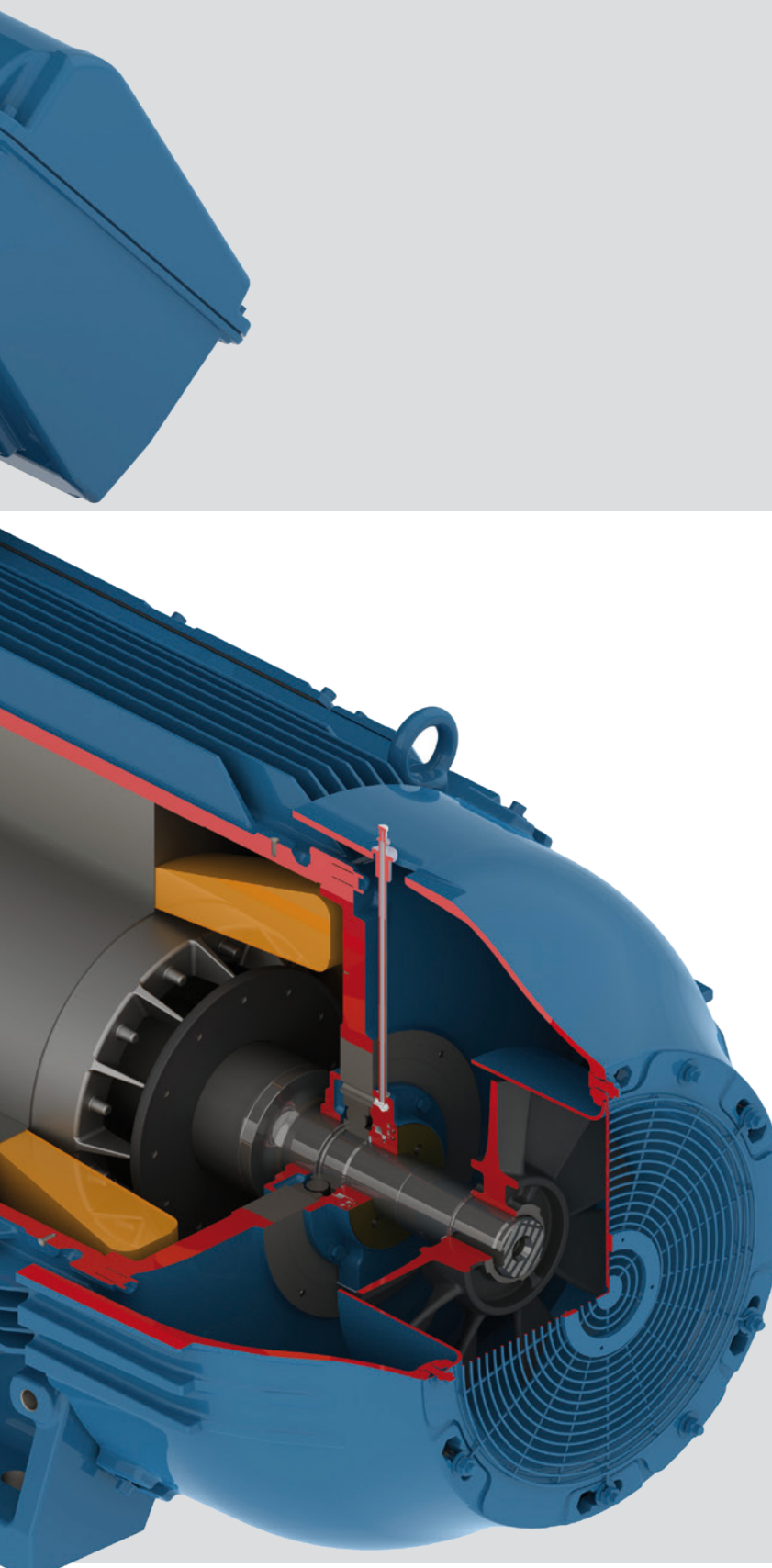

## Dedicated W50 lines

The W50 motors also feature a number of definite purpose versions, developed to meet specific industry and application requirements, whilst maintaining the need to provide the best solution for the customer.

### **W50Xec**

With safety being of paramount importance, WEG developed the W50 Increased Safety (Ex ec) motors line to operate in hazardous areas. This type of protection is applied to electrical equipment which does not cause ignition of an explosive atmosphere under normal operating conditions.

- Suitable for operation in IEC hazardous areas classified as Zone 2, Group II, Temperature class T3
- Compliance with NEC standard requirements regarding hazardous areas, such as Class I, Division 2, Groups B, C and D, Temperature Class T3





### W50 IEEE 841

The W50 IEEE841 motors are specially suited for Pulp & Paper mills, Steel mills, Petrochemical Plants and diverse demanding applications requiring severe duty long life motors.

- Internal anticorrosive painting
- Guaranteed foot flatness to within 0.005"
- T-type open drain made of stainless steel 304
- INPRO/SEAL® bearing seal

### W50 API 541

The W50 API 541 line was specially developed in accordance with the requirements of the American Petroleum Institute, the World reference in the standardization of equipment for the oil industry.

- Certified for ambient temperatures up to 60 °C
- Copper rotor
- Sleeve bearings
- Maximum Is/In of 6.5
- Stainless steel fasteners



**ABM TECNA**

**Rue des sources 5  
6220 FLEURUS**

**Belgium**

**Phone : +32 71 85 85 00**

**Email : [commercial@abm-tecna.be](mailto:commercial@abm-tecna.be)**

More information : <https://www.abm-tecna.be/>



**Cod: 50043840 | Rev: 04 | Date (m/a): 02/2021.**

The values shown are subject to change without prior notice.  
The information contained is reference values.